

Chapter 7

MediaFLO Technology: FLO Air Interface Overview

Qiang Gao, Murali Chari, An Chen, Fuyun Ling, and Kent Walker

7.1 Introduction

MediaFLO™ is a mobile broadcast technology based on open and global standards. A key component of MediaFLO is the FLO™ (Forward Link Only) air interface technology which has multiple published Telecommunications Industry Association (TIA) [13] specifications. FLO is also recognized by ITU-R as a recommended technology for mobile broadcasting and is in the approval process at the European Telecommunications Standards Institute (ETSI). Global standardization efforts are driven and supported by the FLO Forum [3], an industry consortia consisting of 90+ member companies throughout the global mobile broadcast value chain. MediaFLO technology has been launched commercially in the United States (USA) through the nationwide mobile broadcast network built by MediaFLO USA, Inc [10]. Verizon Wireless has deployed MediaFLO services in 50 U.S. markets, and AT&T expects to launch commercial services in early 2008 leveraging the MediaFLO USA network. In addition, MediaFLO technology is being trialed in major markets around the world.

Unlike other mobile broadcast technologies that have evolved from legacy systems, MediaFLO was designed from the ground up for the mobile environment. Consequently, it can deliver mobile broadcast services in a very efficient manner and offers unique advantages such as low receiver power consumption, fast channel switching time, robust reception in mobile fading channels, high spectral efficiency and efficient statistical multiplexing of service channels. MediaFLO technology achieves all of these advantages simultaneously without compromising one for another.

Figure 7.1 shows the MediaFLO protocol stack on the interface between the MediaFLO network and the MediaFLO device. The FLO Air Interface specification consists of Physical Layer, MAC (Medium Access Control) Layer, Control Layer

Q. Gao (✉), M. Chari, A. Chen, F. Ling, and K. Walker
Qualcomm Inc., San Diego, CA 92121, USA
e-mail: qgao@qualcomm.com

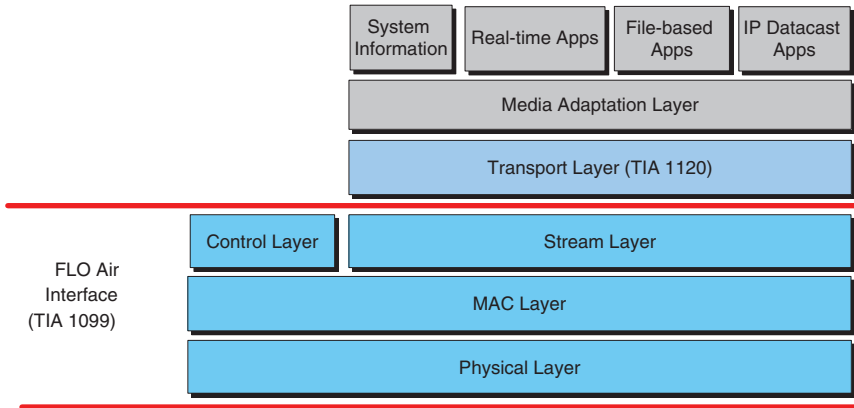

Fig. 7.1 MediaFLO protocol suite

and Stream Layer. The Transport Layer [5] forms a sequence of application service packets for a service component such as video and audio into fixed-size blocks or an octet stream every second for delivery over the Stream Layer. The Media Adaptation Layer provides adaptations that are specific to the class of content being transported, such as real-time streaming services, non-real-time services and IP (Internet Protocol) datacast packets.

This chapter gives an overview of the FLO Air Interface (standardized in TIA-1099 [4]). The rest of this chapter is organized as follows: Section 7.2 presents the overall layering architecture of the FLO Air Interface. Section 7.3 is devoted to the Physical Layer of the FLO system including Orthogonal Frequency Division Multiplexing (OFDM) modulation characteristics, interlace structure, superframe structure, Physical Layer subchannels, and waveform generation for data and OIS (Overhead Information Symbol) channels. The MAC Layer of the FLO system is addressed in Sect. 7.4 with coverage on data encapsulation, Reed-Solomon code and time-frequency resource allocation to services. Sections 7.5 and 7.6 deal with the Control Layer and Stream Layer, respectively. In Sect. 7.7, the FLO Air Interface handling scenarios at the FLO receiver including MLC (Multicast Logical Channel) reception and MLC switching are given.

7.2 FLO Air Interface Layering Architecture

The description on the FLO Air Interface in this section is based on the TIA-1099 standard published in Aug 2006 [4]. Future revisions of the standard may add new features and enhancements.

A MediaFLO service is an aggregation of one or more data components. Each data component of a service is called a *flow*. For example, a MediaFLO TV service may have a video flow, an audio flow, a subtitle flow and a signaling flow. Services

are classified into two types based on their coverage: wide-area services and local-area services (Fig. 7.2). A local-area service is typically multicast for reception within a metropolitan area while a wide-area service is typically multicast in one or more metropolitan areas.

MediaFLO services and control information may be carried over one or more logical channels called MLCs. An MLC may be divided into a maximum of three logical subchannels called streams. Each application flow is mapped to a single stream in an MLC. The flows belonging to a single instance of a MediaFLO service may be sent over multiple MLCs within a single RF allocation, e.g. one 6 MHz channel. The MLCs are multiplexed to the FLO Physical Layer data channel. The relationship of flows, streams, MLCs and Physical Layer data channels is illustrated in Fig. 7.3. Note that although MLC is a MAC Layer concept, it is distinguishable at the Physical Layer. This is an important feature for mobility since it enables access to fraction of the Physical Layer bandwidth without demodulating the entire waveform.

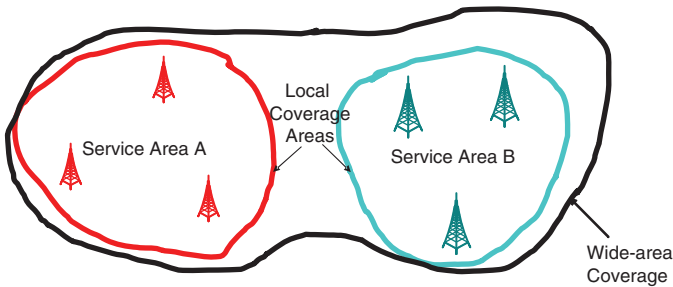

Fig. 7.2 Local-area and wide-area services

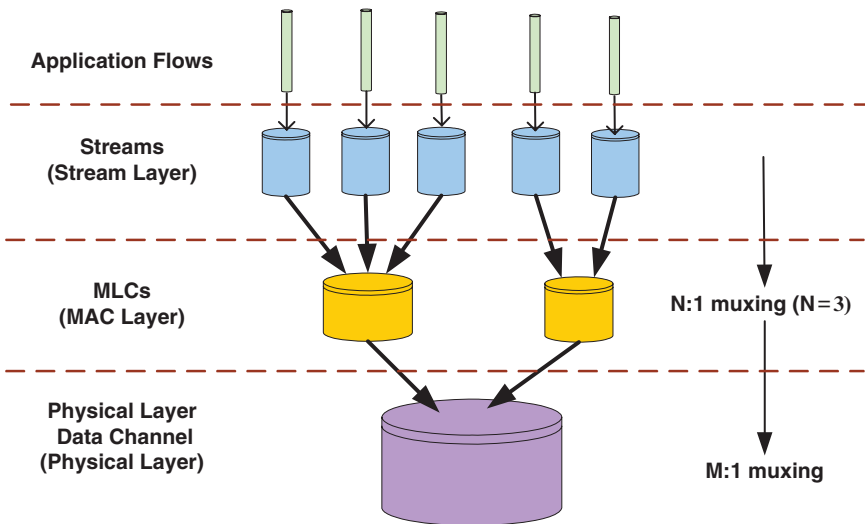

Fig. 7.3 Flows, streams, MLCs and Physical Layer data channels

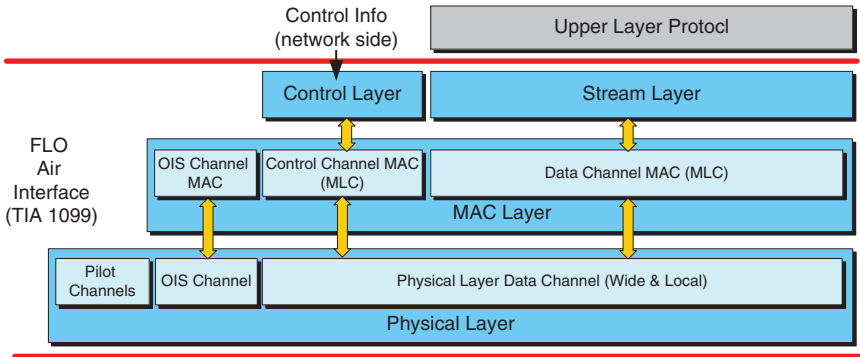

Fig. 7.4 FLO Air Interface layering architecture

Figure 7.4 depicts the FLO Air Interface layering architecture:

- *Physical Layer:* The Physical Layer provides the channel structure, frequency, modulation and encoding specification for the Forward Link.
- *MAC Layer:* The MAC Layer defines the procedures used to receive and transmit over the Physical Layer. It is responsible for resource allocation on the Physical Layer data channel. The MAC Layer also multiplexes packets belonging to different media streams associated with the same MLC.
- *Stream Layer:* The Stream Layer binds Upper Layer flows to streams and MLCs.
- *Control Layer:* This layer is used by the network to disseminate control information to facilitate the device operation in the MediaFLO system. The device uses the Control Layer to maintain synchronization of its control information with that in the network.
- *Upper Layers:* The Upper Layer protocols provide multiple functions including encoding of multimedia content, controlling access to the multimedia content and formatting of control information.

7.3 Physical Layer

7.3.1 OFDM Modulation Characteristics

MediaFLO network deployment is typically based on the concept of SFN¹ (Single Frequency Network) [8]. In such a network, multiple transmitters transmit identical waveforms from time synchronized transmitters. The signals from these transmitters can be viewed by the receiver as multipath signals from the same source but with different propagation delays. The distance between transmitters in a mobile broadcast network can possibly be large (20 ~ 30km), which can cause large delay spreads

¹ FLO also supports Multiple Frequency Network deployment.

Table 7.1 FLO OFDM parameters

Parameters	Value
RF channel bandwidth	6 MHz
Chip rate (FFT bandwidth)	5.55 MHz
Chip duration	0.18018 μ s
Number of subcarriers (FFT size)	4,096
Subcarrier spacing	1.355 KHz
FFT interval (useful OFDM symbol interval)	738.02 μ s (4,096 chips)
Cyclic prefix (flat guard interval)	92.25 μ s (512 chips)
Window interval	3.06 μ s (17 chips)
(Effective) OFDM symbol interval	833.33 μ s (4,625 chips)
Number of guard subcarriers	96
Number of active subcarriers	4,000
Number of pilot subcarriers	500

up to or more than 100 μ s (as opposed to 5–6 μ s in cellular networks). OFDM is a form of multicarrier modulation that is especially suitable for the radio environment with large multipath delay spreads. OFDM receivers are also simple to implement as they do not require complicate equalizer or more specifically the equalization and demodulation are executed jointly. For these reasons, MediaFLO uses OFDM as the modulation technique.

The FLO Physical Layer supports transmission in radio frequency bands with RF channel bandwidths of 5, 6, 7 and 8 MHz. The description in this chapter assumes a 6 MHz RF channel bandwidth with the parameters specified in Table 7.1, unless otherwise stated. The system parameters for all the RF channel bandwidths supported by FLO are listed in the Appendix.

For an RF channel of 6 MHz, the FLO OFDM subcarriers span a bandwidth of 5.55 MHz, which is called the *chip rate*.² The chip rate is 92.5% of the allocated RF bandwidth in order to meet regulatory requirements for the transmit spectral mask. The frequency location of the 4,096 subcarriers at base band is given by

$$f_{SC}(i) = (i - 2048) \times (\Delta f)_{SC}, \quad i = 0, 1, \dots, 4095$$

where i is the subcarrier index and $(\Delta f)_{SC}$ is the subcarrier spacing given by

$$(\Delta f)_{SC} = \frac{\text{chip rate}}{\text{number of subcarriers}} = \frac{5.55 \times 10^6}{4096} = 1.35498046875 \text{ kHz}$$

The 96 subcarriers with indices 0, ..., 47, 2,048, 4,049, ..., and 4,095 are not used and referred to as *guard subcarriers* (Fig. 7.5). The subcarrier 2,048 corresponds to DC. The 95 guard subcarriers on each side make it easier for the FLO receiver to cope with the adjacent channel interference. The remaining 4,000 subcarriers are referred to as *active subcarriers* that are modulated by data or pilot symbols.

² The chip rates for 5, 7 and 8 MHz RF channel bandwidths are 4.625, 6.475 and 7.4 MHz, respectively.

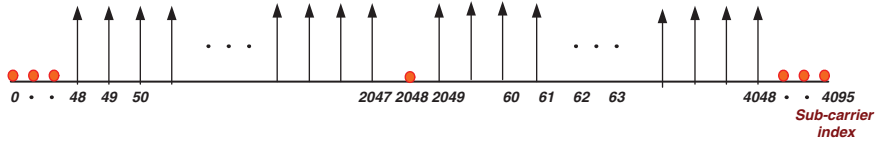

Fig. 7.5 Guard and active subcarriers

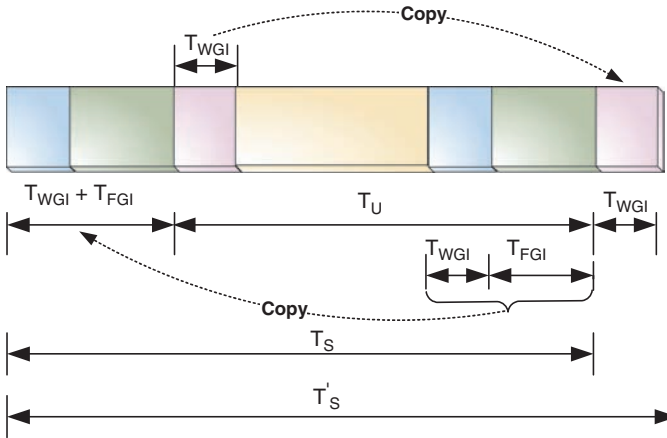

Fig. 7.6 OFDM symbol time-domain structure

The OFDM symbol time-domain structure is shown in Fig. 7.6. At base band, it consists of a number of time-domain samples called *OFDM chips*, which are transmitted at the chip rate 5.55 MHz (chip duration 0.18018 μs). The total OFDM symbol interval T'_s is comprised of four parts:

- T_U : The useful part with duration 4,096 chips. This is also duration of the FFT interval.
- T_{FGI} : The flat guard interval (also known as cyclic prefix) with duration 512 chips (1/8th of T_U). This duration of cyclic prefix allows for a multipath channel with delay spread up to $512 \times 0.18018 = 92.25 \mu s$ which corresponds to 27.7 km path length difference without either inter-symbol interference or inter-carrier interference at the receiver [12].
- A raised cosine windowed interval of duration $T_{WGI} = 17$ chips is implemented on the beginning and end of each symbol.

The OFDM symbol is windowed by the following raised cosine function:

$$w(t) = \begin{cases} 0.5 + 0.5 \cos(\pi + \pi t / T_{WGI}) & 0 \leq t \leq T_{WGI} \\ 1 & T_{WGI} < t < (T_{WGI} + T_{FGI} + T_U) \\ 0.5 + 0.5 \cos(\pi + \pi(T'_s - t) / T_{WGI}) & (T_{WGI} + T_{FGI} + T_U) \leq t \leq (2T_{WGI} + T_{FGI} + T_U) \end{cases}$$

The purpose of the windowing function is to improve the spectral mask of the based-band OFDM signal by attenuating the side-bands. As shown in Fig. 7.7, two

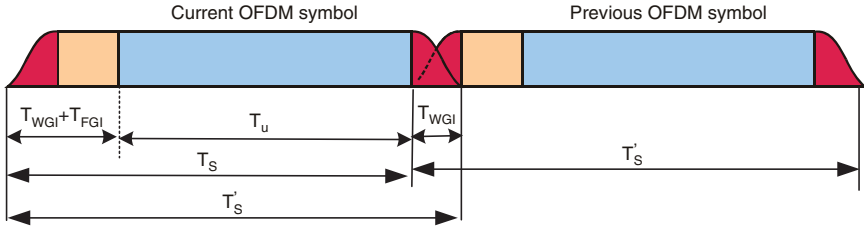

Fig. 7.7 Overlap of Windowed OFDM Symbols

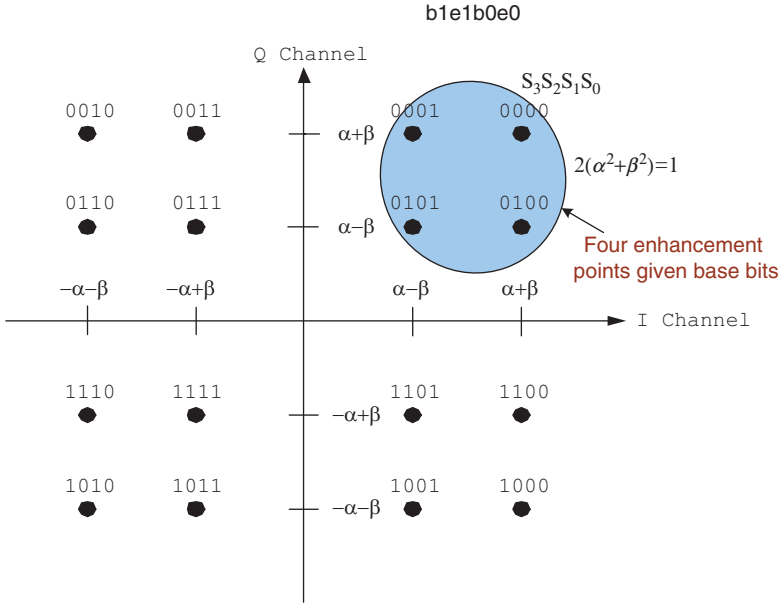

Fig. 7.8 Layered QPSK Signal Constellation

consecutive OFDM symbols overlap by T_{WGI} . Hence, the *effective OFDM symbol interval* is $T_s = T_{WGI} + T_{FGI} + T_U = 4625$ chips. The effective OFDM symbol interval is also referred to as the OFDM symbol interval. During an OFDM symbol interval, a modulation symbol is carried on each of the active subcarriers.

Each active subcarrier is modulated by QPSK, 16-QAM or Layered QPSK (16 states). If Layered QPSK is used, the data stream is divided into base layer and enhancement layer. Two base layer bits $b1b0$ and two enhancement layer bits $e1e0$ are combined to $b1e1b0e0$ and mapped to a uniform or nonuniform 16-QAM signal constellation (Fig. 7.8). The two base layer bits $b1b0$ determine the quadrant the signal point resides in and the two enhancement layer bits $e1e0$ determine the exact location of the signal point within the quadrant selected by the two base layer bits. The enhancement bits can be successfully decoded only by users with higher SNR. In Fig. 7.8, the energy ratio between the base layer and the enhancement layer is α^2/β^2 . It is equal to either 4.0 or 6.25 in FLO standard.

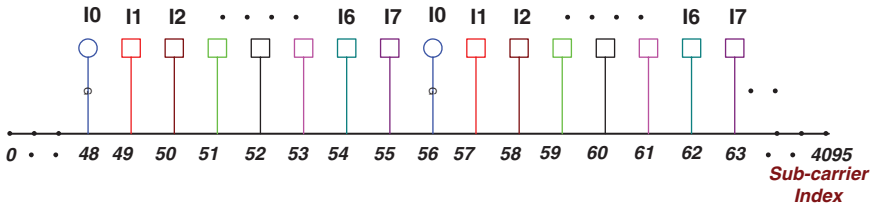

Fig. 7.9 FLO Interlace Structure

Layered modulation is suitable for applications that can produce base layer and enhancement layer bit streams associated with the same service. For example, a video application can use base layer bits to represent the basic details of the video and the enhancement layer bits to represent the fine details.

7.3.2 Interlace Structure

The 4,000 active subcarriers are divided into eight disjoint and equally sized groups called *interlaces*. The interlaces are indexed from 0 to 7. A subcarrier with index i belongs to the interlace with index equal to $i \text{ modulo } 8$. Therefore, the 500 subcarriers each interlace has are evenly spaced and span the total FLO signal bandwidth (Fig. 7.9). An interlace is the minimum frequency allocation unit the system can allocate to an MLC within an OFDM symbol. It enables the frequency-division multiplexing of MLCs and allows for fine granularity of bandwidth allocation to MLCs. Since the subcarriers within an interlace span the total FLO signal bandwidth, there is no loss of frequency diversity within an interlace.

Slot is a concept closely related to interlace. A slot corresponds to a group of 500 constellation symbols. It is the smallest unit of bandwidth allocated to an MLC over an OFDM symbol. Each slot is mapped to one interlace (see Sect. 7.3.4). The eight slots are also indexed from 0 to 7. Note that the term *interlace* refers to a group of subcarriers, while the term *slot* refers to a group of constellation symbols and is defined for bandwidth allocation purposes.

7.3.3 Superframe Structure and Physical Layer Subchannels

7.3.3.1 Superframe Structure

The FLO transmitted signal is organized into superframes. Each superframe has duration 1 s, and consists of 1,200 OFDM symbols for a 6 MHz RF allocation. This is 200 symbols per MHz which is a common feature of all bandwidths. The OFDM

symbols in a superframe are numbered 0 through 1,199. [Figure 7.10](#) shows the FLO superframe structure. A superframe has four main portions:

- *TDM pilots*: The four OFDM symbols at the beginning of each super frame are TDM pilot 1 (TDM1), Wide-area Identification Channel (WIC), Local-area Identification Channel (LIC), and TDM pilot 2 (TDM2). TDM1 marks the beginning of a superframe. It can be used for superframe synchronization, initial frequency synchronization and coarse timing determination. The WIC and LIC symbols carry the WID (Wide-Area Differentiator) and LID (Local-Area Differentiator), respectively. Wide areas broadcasting the same wide-area service are allocated the same WID, and local areas broadcasting the same local-area services are allocated the same LID and WID. The TDM2 symbol is used for fine timing determination so the receiver can immediately start decoding the OIS symbols (see below). It can also be used to generate an initial estimate of the channel.
- *OIS*: The OIS portion has two sections: the Wide-Area OIS and the Local-Area OIS. Each section consists of five OFDM symbols. The Wide-Area OIS and the Local-Area OIS carry overhead information regarding the wide-area and local-area data channels (see below), respectively. The overhead information is the time-frequency allocation for each MLC in the current superframe (see Sect. 7.4.3).
- *Data frames*: The data portion has four data sections of equal duration, called *frames*. The frames are used to transmit MLCs. When an MLC is transmitted in a superframe the payload is divided into four equal bursts, with each burst transmitted in a *unique* frame. To support wide-area and local-area services (explained in Sect. 7.2), each data frame is further divided into two parts: the Wide-Area Data Channel for carrying wide-area service data and the Local-Area Data Channel for carrying the local-Area service data. The numbers of OFDM symbols for the Wide-Area and Local-Area data channels are specified by the information carried in the Wide-Area and Local-Area OIS channels, respectively.
- *Positioning Pilot Channel (PPC)/Reserved Symbols*: This portion is either the PPC or Reserved Symbols. The number of the OFDM symbols allocated to this portion is specified by the information carried in the OIS. The PPC symbols carry unique information for each transmitter and can be used for transmitter identification and/or the FLO receiver positioning based on the measured distances to transmitters. They will be completely defined in the future revisions of the FLO Air Interface standard.

There is an OFDM symbol, called the Transition Pilot Channel (TPC) symbols, on each side of every Wide- and Local-Area OIS or Wide- and Local-Area Data Channels. The TPC symbols are used to assist channel estimation at the boundary between the Wide- and Local-Area channels for demodulation of the OIS or data OFDM symbols adjacent to them. They also facilitate timing synchronization for the first Wide-Area or Local-Area MLC in each data frame.

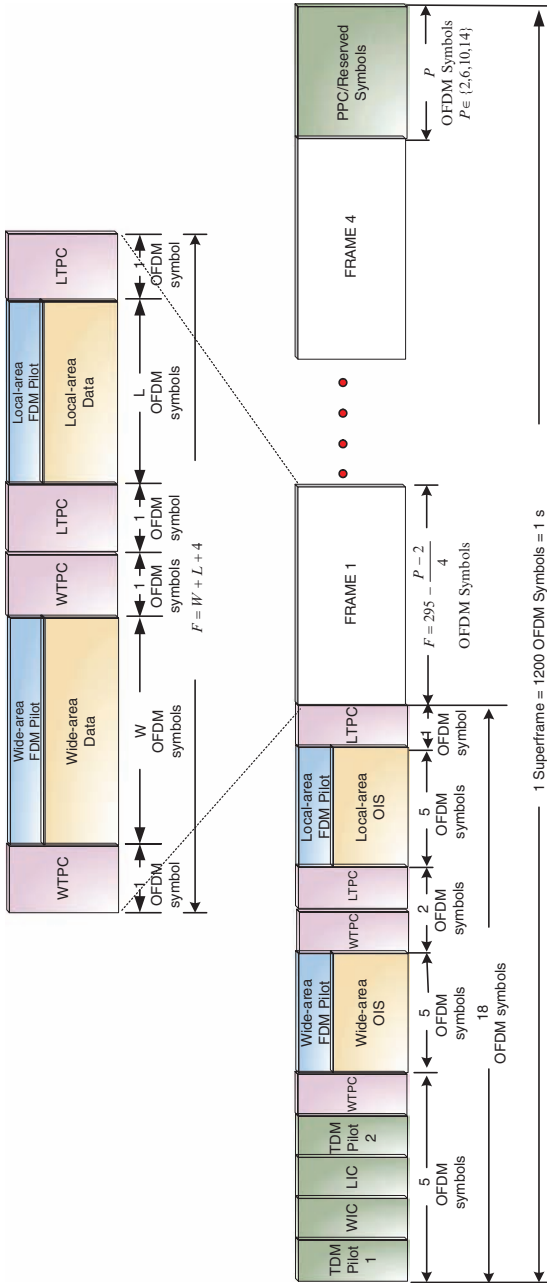

Fig. 7.10 FLO superframe structure

7.3.3.2 Impact of Superframe Duration

The FLO superframe duration was chosen to be 1 s based on the good trade-off among the following performance metrics:

- *Channel switching time*: A longer superframe duration leads to longer channel switching time. This is explained in Sect. 7.7.2.
- *Time diversity*: FLO enables data recovery for an MLC from data loss over the duration of up to one or two frames with the use of Reed-Solomon code as explained in Sect. 7.4.2, especially at code rate 8/16 or 12/16. The frame duration needs to be as large as the channel coherence time to allow de-correlation of the transmission in frames and provide time diversity gain. The Doppler frequency for an FLO receiver operating at 719 MHz with a velocity of 3 kmph is 2 Hz, which translates to a 212 ms coherence time. The coherence time is calculated by $0.423/\text{Doppler frequency}$ [6].
- *Statistical multiplexing gain*: the MediaFLO network dynamically allocates bandwidth (time-frequency resource allocation) to the multiple active MLCs on a per-superframe basis (see Sect. 7.4.3). The longer the superframe duration, the lower the standard deviation of the aggregate capacity allocation, and the greater the effective gain in capacity.
- *Receiver decoding buffer size and video/audio delay*: A longer superframe duration leads to a larger decoding buffer on the receiver and longer latency for the video and audio data.

7.3.3.3 Physical Layer Subchannels

The FLO Physical Layer Subchannels are shown in Fig. 7.11. The allocated subcarriers or interlaces, subcarrier modulation, error control coding and carried data on the subchannels are summarized in Table 7.2 (the scrambling PN sequences are generated by the method described in Sect. 7.3.4).

The data transmitted in each subchannel except for the TDM Pilot 1 is scrambled by a bit sequence that depends on the subchannel type, OFDM symbol index and slot index (see the Scrambling subsection in Sect. 7.3.4). Basically, all waveforms

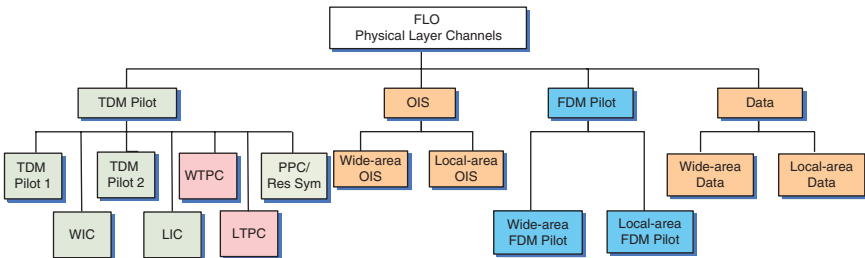

Fig. 7.11 FLO Physical Layer subchannels

Table 7.2 Summary of Physical Layer subchannels' transmission characteristics

Physical Layer subchannels	Allocated subcarriers or interlaces	Modulation and coding	Carried data
TDM1	One hundred and twenty-four evenly spaced subcarriers	QPSK	TDM Pilot 1 Information packet, a 248-bit fixed pattern from a PN-sequence
WIC	Interlace 0	QPSK	One thousand bits all-zero sequence scrambled by a PN sequence based on the WID assigned to the transmitter
LIC	Interlace 0	QPSK	One thousand bits all-zero sequence scrambled by a PN sequence based on the Wide-area Differentiator and the LID assigned to the transmitter
TDM2	Two thousand evenly spaced subcarriers (four interlaces)	QPSK	One thousand bits all-zero sequence scrambled by a PN sequence
WTPC/ LTPC	All eight interlaces	QPSK	One thousand bits all-zero sequence scrambled by a PN sequence on slot 0. A 1,000 bit fixed pattern (generated by an 11-tap linear feedback shift register) scrambled by a PN sequence on slot 1 to 7
FDM Pilot	One interlace (2 or 6)	QPSK	One thousand bits all-zero sequence scrambled by a PN sequence
OIS	Seven interlaces	QPSK, 1/5 Turbo code (Transmit Mode 5)	OIS overhead information
Physical Layer Data Channel	Seven interlaces	Modulation and coding on an interlace depends on the transmit mode of the MLC the interlace is allocated to	Service application data or control information

transmitted within a wide area are scrambled using the 4-bit WID corresponding to that area, and all waveforms transmitted within a local area are scrambled using a 4-bit LID, in conjunction with the WID, corresponding to that area. The WID and LID are transmitted in the WIC and LIC, respectively. The control information transmitted in the local control channel (see Sect. 7.5) also contains WID and LID for each of the neighboring local area. The purposes of the scrambling are explained in [2].

7.3.4 Waveform Generation for Data and OIS Channels

FLO services and control information are carried in logical channels called MLCs. An active MLC is allocated some slots in some OFDM symbols in a data frame and all active MLCs are multiplexed into the same data frame as described in Sect. 7.4.3.

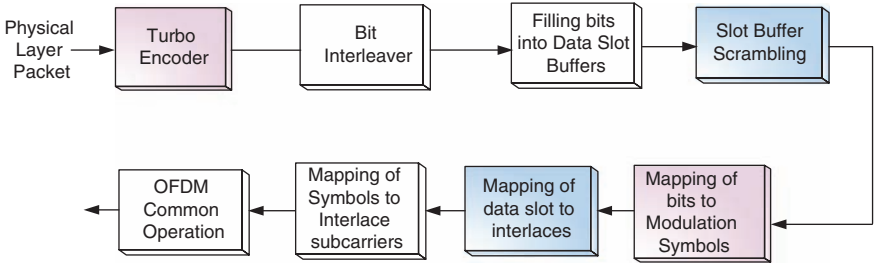

Fig. 7.12 Procedure to Generate Data Channel waveform contributed by an MLC

Table 7.3 FLO transmit modes and spectral efficiency

Transmit Mode	Modulation	Turbo code rate	Physical Layer data rate (Mbps)	Spectral efficiency (bps/Hz)
0	QPSK	1/3	2.8	0.47
1	QPSK	1/2	4.2	0.70
2	16-QAM	1/3	5.6	0.93
3	16-QAM	1/2	8.4	1.40
4	16-QAM	2/3	11.2	1.86
5 ^a	QPSK	1/5	1.68	0.28
6	Layered QPSK with energy ratio 4	1/3	5.6	0.93
7	Layered QPSK with energy ratio 4	1/2	8.4	1.40
8	Layered QPSK with energy ratio 4	2/3	11.2	1.86
9	Layered QPSK with energy ratio 6.25	1/3	5.6	0.93
10	Layered QPSK with energy ratio 6.25	1/2	8.4	1.40
11	Layered QPSK with energy ratio 6.25	2/3	11.2	1.86

^aThis mode is used for the OIS channels only.

Figure 7.12 shows the procedure to generate the Physical Layer Data Channel waveform contributed by a particular MLC (OIS is a special case of data channels and uses the same procedure). The Turbo code rate and subcarrier modulation type for an MLC or OIS are specified by their transmit mode. The transmit modes defined in the FLO standard are shown in Table 7.3, along with the Physical Layer data rates,³ and spectral efficiency for each transmit mode. Note that OIS always uses transmit mode 5. The transmit mode for the MLC mapped to a wide-area or local-area control channel (see Sect. 7.5) in a superframe is specified by the overhead information carried in the corresponding wide-area or local-area OIS channel in the same

³ The Physical Layer data rates for all the RF channel bandwidths supported by FLO are listed in the Appendix.

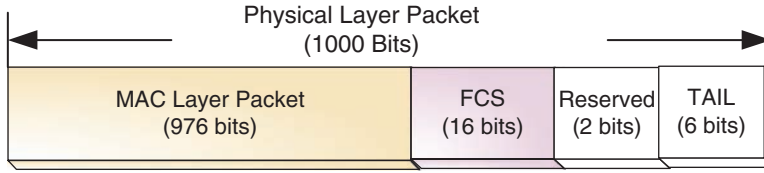

Fig. 7.13 FLO Physical Layer packet structure

superframe. The transmit modes for all other MLCs in the superframe are specified by the control information carried in the corresponding control channels in the same superframe.

7.3.4.1 Physical Layer Packet

The Physical Layer packet (PLP) is the unit of data transmission in the FLO Physical Layer. As shown in Fig. 7.13, a PLP has 1,000 bits in total and its payload size of 976 bits is equal to the MAC Layer packet size. The FCS (Frame Check Sequence) bits are 16 CRC bits calculated using the standard CRC-CCITT generator polynomial:

$$g(x) = x^{16} + x^{12} + x^5 + 1$$

The FCS bits are used by the receiver to determine if the PLP was correctly decoded or not.

7.3.4.2 Turbo Encoding

The PLPs are encoded by Turbo code derived from the Turbo codes defined in the CDMA2000 and 1x-EV-DO standards [1, 11]. In the FLO standard, the Turbo code is also referred as the inner code as compared to the Reed-Solomon code based outer code done on the MAC Layer. It is mainly used to exploit the frequency-diversity inherent in the channel. The FLO standard defines Turbo code rates of 1/3, 1/2 and 2/3. An MLC's Turbo code rate is specified by its transmit mode. The OIS uses code rate specified in transmit mode 5. The encoded PLPs are called Turbo Encoded Packets (TEP).

7.3.4.3 Bit Interleaving

The output bits of the Turbo encoder are bit-interleaved. The purpose of interleaving is to ensure that consecutive bits in the receiver's Turbo decoder input are transmitted on subcarriers that are sufficiently separated in the frequency domain such that they experience uncorrelated fading. This helps to disperse error bursts in the

received PLP and increases the probability that the decoder will recover the encoded PLP as whole. Please refer to [4] for more details on the interleaver.

7.3.4.4 Filling Slot Buffers

Slots are allocated to MLCs at the MAC Layer. The TEPs of MLCs are transmitted in the slots allocated to the MLC. Slot allocations are done in such a way that multiple MLCs do not share the same slots within an OFDM symbol.

7.3.4.5 Scrambling

The bits in each allocated slot buffer are XORed sequentially with a scrambling bit sequence to randomize the bits prior to modulation.

As shown in Fig. 7.14, the scrambling bit sequence is generated according to the following procedure:

- For each slot at the start of every OFDM symbol, the state of the 20-tap linear feedback shift register with the generator sequence $h(D) = D^{20} + D^{17} + 1$ is initialized to $[d_3d_2d_1d_0c_3c_2c_1c_0b_0a_{10}a_9a_8a_7a_6a_5a_4a_3a_2a_1a_0]$ that depends on the channel type and the OFDM symbol index as summarized in Table 7.4.
- The scrambling bit sequence is generated by a modulo-2 inner product of the state vector of the linear feedback shift register and a 20-bit mask associated with the slot index. The mask is chosen based on the slot index according to Table 7.5. The purpose of the mask is to divide the LFSR's state space into eight nonoverlapping segments so that each slot corresponds to a unique segment.

In general, the scrambling bit sequence depends on the channel type, OFDM symbol index and the slot index.

7.3.4.6 Slot to Interlace Mapping

The FLO system allocates time-frequency resources to FDM pilots, OIS and MLCs based on slots. The slots are mapped to interlaces on the Physical Layer. Figure 7.15 shows the mapping pattern that repeats after 14 consecutive OFDM symbols. The numbers in boxes are interlace indices. Slot 0 is always used for FDM pilot and mapped to interlace 6 and 2 alternatively on a per OFDM symbol basis.

The slot-to-interlace mapping for OIS and MLCs distributes their transmission over all interlaces in multiple OFDM symbols despite the fact that they are allocated a fixed set of slots within a superframe, which improves the performance on channels with periodic nulls. The mapping for the FDM pilots doubles the maximum channel multipath delay spread that can be estimated as explained earlier.

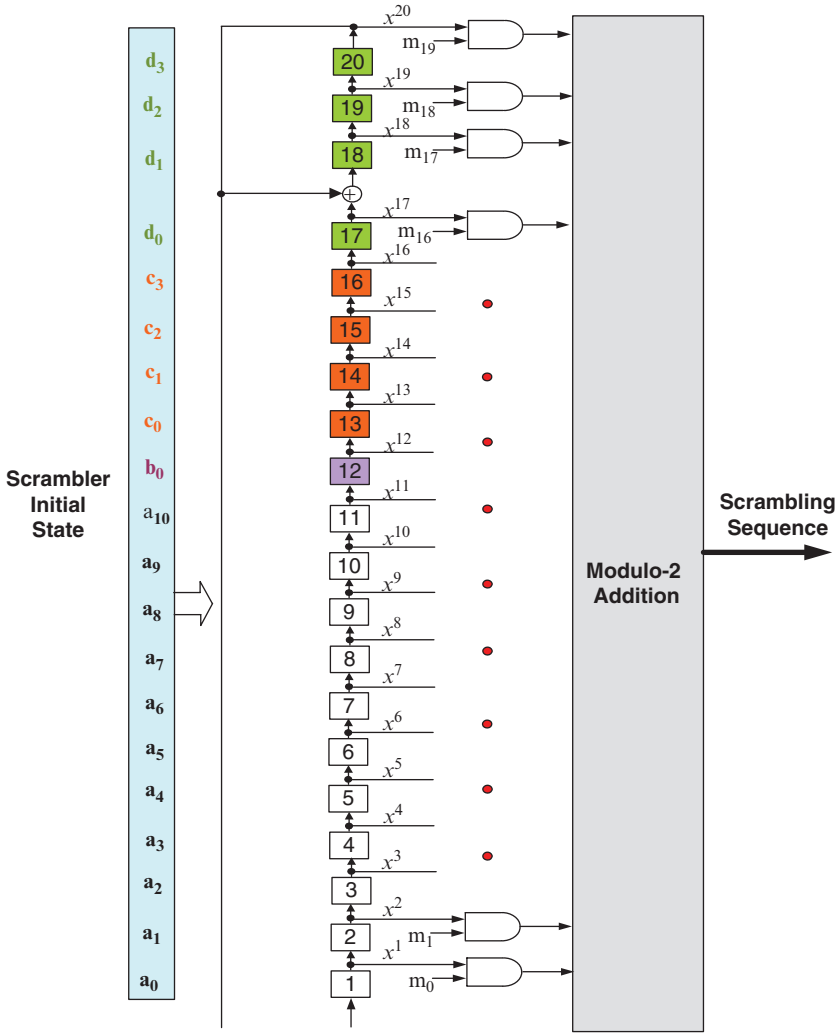

Fig. 7.14 Scrambling bit sequence generator

7.3.5 FDM Pilots

The FLO system uses one interlace as FDM pilots when the OIS or data frames are transmitted (Fig. 7.10). The FDM pilot is frequency division multiplexed with OIS or data channels (Fig. 7.16). The FDM pilot carries known modulation symbols and is used for channel estimation [7]. The subcarriers of the pilot interlace are modulated with QPSK symbols with the same energy as the MLC constellation symbols on the other interlaces.

Table 7.4 Initial state for the linear feedback shift register in the scrambling bit sequence generator

	D3d2d1d0	C3c2c1c0	b0	a10a9a8a7a6a5a4a3a2a1a0
TDM Pilot 2	WID	0000	1	Equal to OFDM symbol index number in a super-frame, which ranges from 0 through 1,199
WIC	WID	0000	1	
WTPC	WID	0000	1	
Wide-area FDM Pilot	WID	0000	1	
Wide OIS	WID	0000	1	
Wide Data	WID	0000	1	
LIC	WID	LID	1	
LTPC	WID	LID	1	
Local-area FDM Pilot	WID	LID	1	
Local OIS	WID	LID	1	
Local Data	WID	LID	1	
PPC/ Reserved	WID	LID	1	
OFDM Symbols				

Table 7.5 Masks associated with different slots

Slot Index	m_{19}	m_{18}	m_{17}	m_{16}	m_{15}	m_{14}	m_{13}	m_{12}	m_{11}	m_{10}	m_9	m_8	m_7	m_6	m_5	m_4	m_3	m_2	m_1	m_0
0	0	0	1	0	0	0	0	0	0	0	0	0	1	0	0	0	0	0	1	0
1	0	1	0	0	0	0	0	0	0	0	0	0	0	0	0	0	1	0	0	0
2	1	0	0	1	0	0	0	0	1	0	0	0	0	1	1	0	0	0	1	1
3	0	0	1	0	0	0	0	0	0	0	0	0	1	0	0	0	0	0	0	0
4	1	1	0	0	0	0	0	0	0	0	1	0	0	0	0	0	0	0	0	0
5	1	0	0	1	0	0	0	0	1	0	0	0	0	1	0	0	0	0	1	0
6	0	1	1	0	0	0	1	0	0	0	0	1	0	0	0	0	1	1	0	0
7	1	0	0	0	0	0	0	0	0	0	0	0	0	0	0	0	0	0	0	0

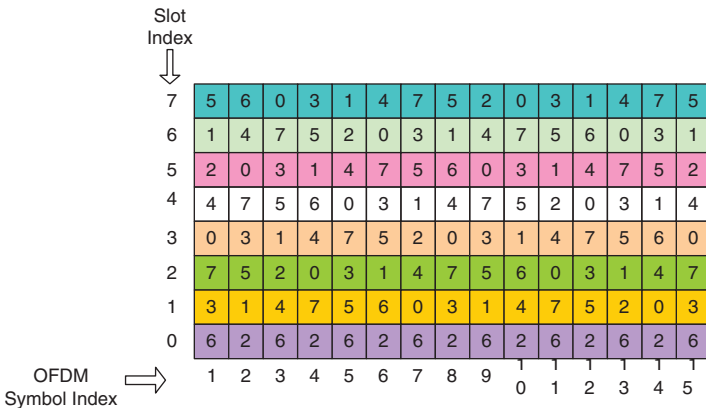

Fig. 7.15 Slot to Interlace Mapping

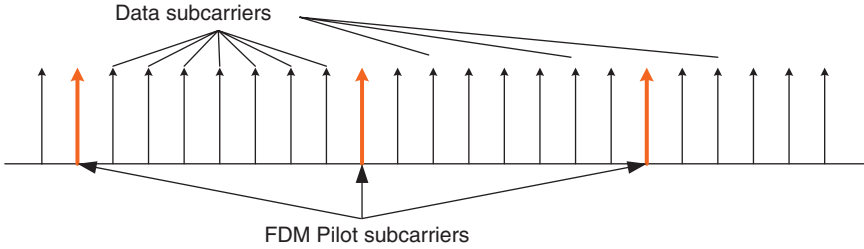

Fig. 7.16 Pilot and data subcarriers

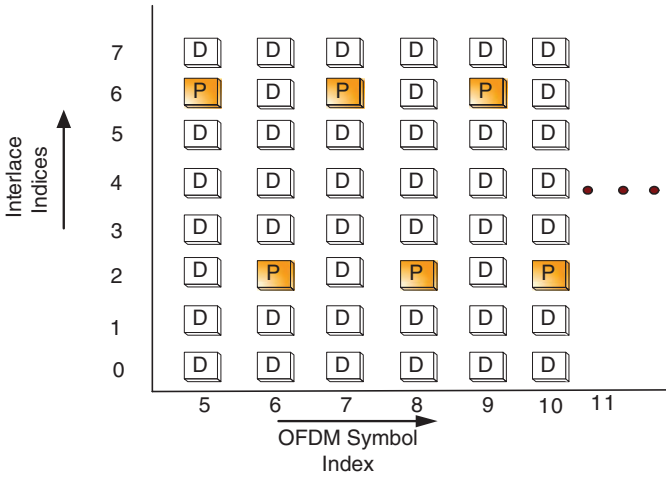

Fig. 7.17 FDM pilot interlaces

The FLO system allocates Slot 0 to the FDM pilot. The remaining seven slots are for OIS or data channels. As shown in Fig. 7.17, Slot 0 is mapped to interlace 2 on OFDM symbols with even indices and interlace 6 on OFDM symbols with odd indices. This allows the FLO receiver to use the pilot observations from two consecutive OFDM symbols to estimate channel with multipath delay spread up to two times the duration of the cyclic prefix (512 chips).⁴ This allows graceful degradation of its performance for channels with multipath delay spreads greater than the cyclic prefix. Receivers in an OFDM system for which the channel multipath delay spread is not longer than the applied cyclic prefix do not experience inter-symbol interference or inter-carrier interference.

⁴ The maximum channel multipath delay spread in chips that can be estimated in an OFDM system is limited by the number of FDM pilot subcarrier observations (FFT outputs corresponding to the pilot).

7.4 MAC Layer

The MAC Layer principally accomplishes the following:

- Defines the data encapsulation format and procedure for the data channels, control channels and OIS channels.
- Performs Reed-Solomon encoding and decoding.
- Allocates time-frequency resources to MLCs.

7.4.1 Data Encapsulation

7.4.1.1 Data Channel MAC

A data channel⁵ is used to carry MediaFLO service data. It is mapped to MLCs. The content of a data channel for one superframe is encapsulated in an entity referred to as Data Channel MAC protocol capsule. [Figure 7.18](#) illustrates how the Data Channel MAC protocol encapsulates Stream layer packets within a Data Channel MAC protocol capsule for an MLC configured for nonlayered mode of operation. Basically, the MAC Layer on the network side does the following:

- Concatenating Stream Layer packets in reverse order of stream ID.
- Adding a MAC Capsule Trailer to the Stream Layer Trailer in the stream 0 packet. The MAC Capsule Trailer has time-frequency allocation for the MLC in the *next* superframe in which the MLC will be present, which is also referred as “embedded OIS.” Note the MAC Capsule Trailer is part of the Stream Layer Trailer.
- Add stuffing packets, if necessary, to make the MAC Protocol Capsule size to be equal to the next integer multiple of Reed-Solomon information block size (as described in Sect. 7.4.2).
- Perform Reed-Solomon encoding and generate parity packets according to Sect. 7.4.2.
- Fragment the MAC Protocol Capsule into MAC Layer packets and send them to the Physical Layer for transmission. A MAC Layer packet is 122 octets in size and forms the payload of one Physical Layer packet (PLP).

Note that the sizes of the Stream Layer packets are always an integer multiple of the MAC packet size (see Sect. 7.6).

The encapsulation for an MLC configured for layered mode is similar and shown in [Fig. 7.19](#). The Base Layer and Enhance ILayer Data Channel MAC protocol capsules have the same size.

The information about the number of MAC Layer packets for each stream in a Wide- or Local-Area MLC in a superframe is transmitted in the Wide- or Local-Area OIS of the same superframe. The MAC Layer on the FLO receiver uses this information to demultiplex MAC Layer packets that are received from an MLC into streams.

⁵ Note it should not be confused with the Physical Layer data channel.

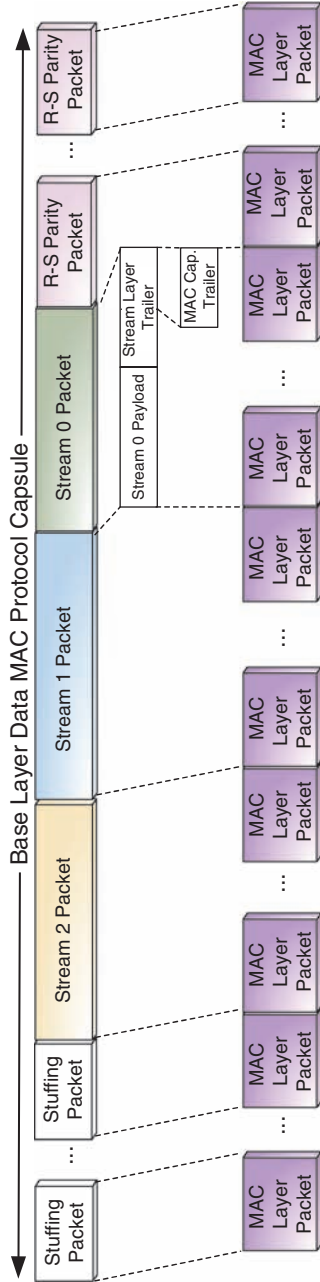

Fig. 7.18 Data Channel MAC protocol encapsulation for nonlayered transmit mode

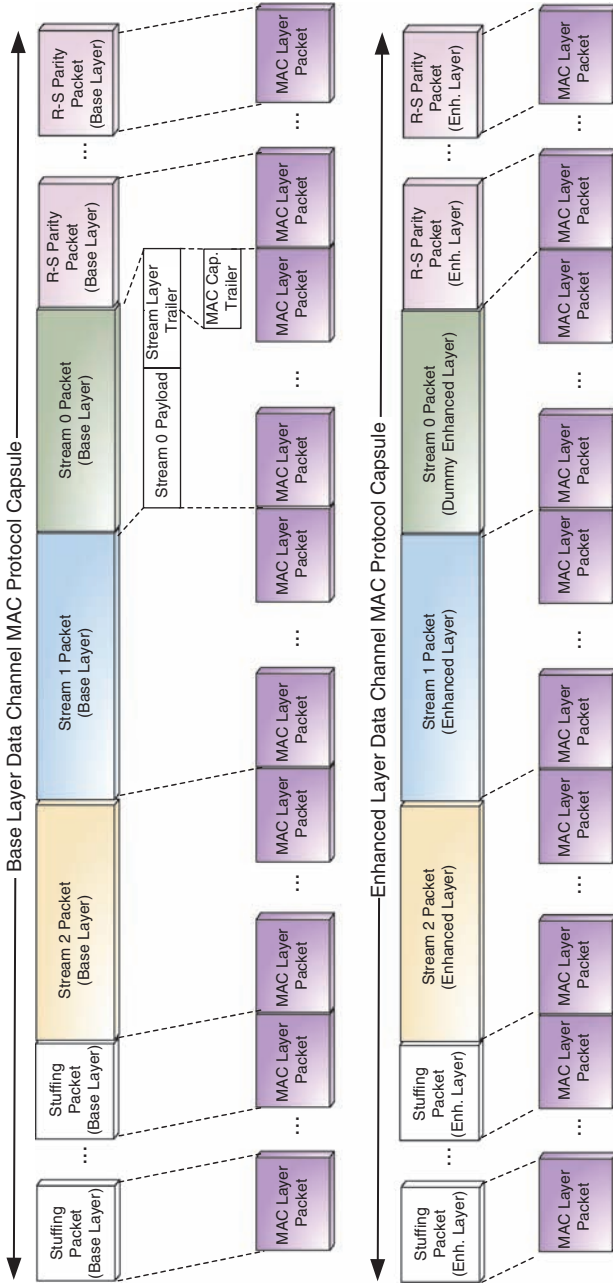

Fig. 7.19 Data Channel MAC protocol Encapsulation for layered transmit mode

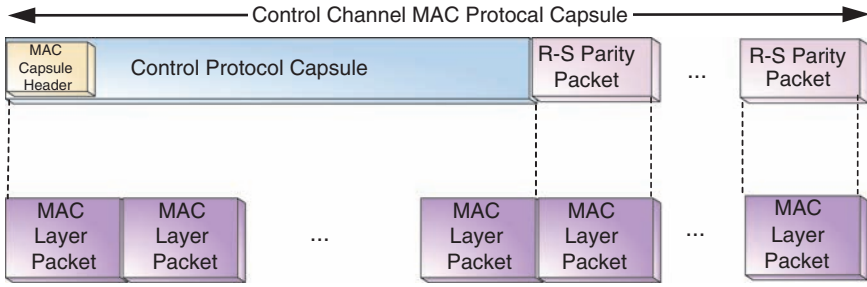

Fig. 7.20 Control Channel MAC protocol encapsulation

7.4.1.2 Control Channel MAC

Control channels are used to carry the overhead information (not carried by the OIS channel) that is needed by FLO receivers to acquire the FLO data channels. Like data channels, these are mapped to MLCs as well. The MLC mapped to a control channel is configured for nonlayered mode operation. The content of a control channel for one superframe is encapsulated in an entity referred to as the Control Channel MAC Protocol Capsule.

Figure 7.20 shows how the Control Channel MAC protocol encapsulates the Control Channel Capsule received from the Control Protocol within the Control Channel MAC Protocol Capsule. Basically, the MAC Layer on the network side does the following:

- Receives the Control Protocol Capsule from the Control Protocol.
- Puts the MAC Capsule Header in the Fill Field of the Control Protocol Capsule. Note that the Fill Field is reserved by the Control Protocol in the Control Protocol Capsule to accommodate the MAC Capsule Header (see Sect. 7.5.1). The Control Protocol Capsule size is always an integer multiple of the MAC Layer packet size.
- Performs Reed-Solomon encoding and generates parity packets according to Sect. 7.4.2.
- Fragments the Control Channel MAC Protocol capsule into MAC Layer packets and send them to the Physical Layer for transmission.

7.4.1.3 OIS Channel MAC

The OIS channels carry overhead information regarding the wide and local data channels such as the time-frequency allocation for each MLC in the current superframe. The overhead information is formatted as the System Parameters Message.

As shown in Fig. 7.21, the OIS Channel MAC Protocol on the network side constructs the System Parameters Message, then breaks in it into MAC Layer packets and passes it to the Physical Layer for transmission.

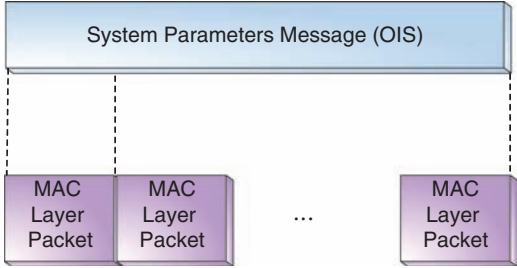

Fig. 7.21 OIS Channel MAC protocol encapsulation

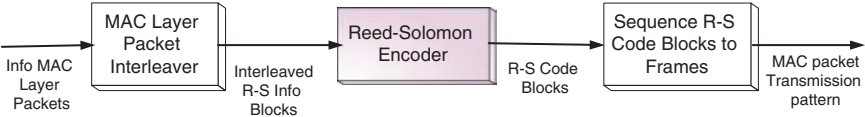

Fig. 7.22 Procedure to protect the Information MAC Layer packets

7.4.2 Reed-Solomon Code

The MAC Layer information packets in an MLC are protected by a (N, K, R) Reed-Solomon code, also referred to as the outer code in the FLO standard. The procedure is shown in Fig. 7.22: the MAC Layer Packet Interleaver receives the information MAC Layer packets formed for each superframe by the methods in Sect. 7.4.1 and generates interleaved Reed-Solomon information blocks that are passed to the Reed-Solomon Encoder. The Reed-Solomon Encoder generates code blocks from the received information blocks and the sequencer delivers the MAC Layer packets in the code blocks in sequence to the Physical Layer for transmission.

Figure 7.23 shows how the Reed-Solomon encodes an interleaved information block:

- Groups the bits in each of the K packets in the information block into 8-bit octets.
- Performs Reed-Solomon encoding on each column of K octets in the information block to generate a codeword of N octets with $R = N - K$ parity octets. The parity octets from all the codewords form $R = N - K$ parity MAC Layer packets. The K information MAC packets and R parity MAC packets form a Reed-Solomon code block.

Note that MLC transmissions in each superframe are always in integer multiples of Reed-Solomon code blocks.

The FLO standard defines the following Reed-Solomon code rates for MLCs: (16, 16, 0), (16, 14, 2), (16, 12, 4) and (16, 8, 8). The Reed-Solomon code rate for an MLC mapped to a control channel is specified in the overhead information (System Parameters Message) transmitted in the OIS while the code rates for all other MLCs are specified in the control information transmitted in the control channels. This is the same method as MLC transmit modes are specified.

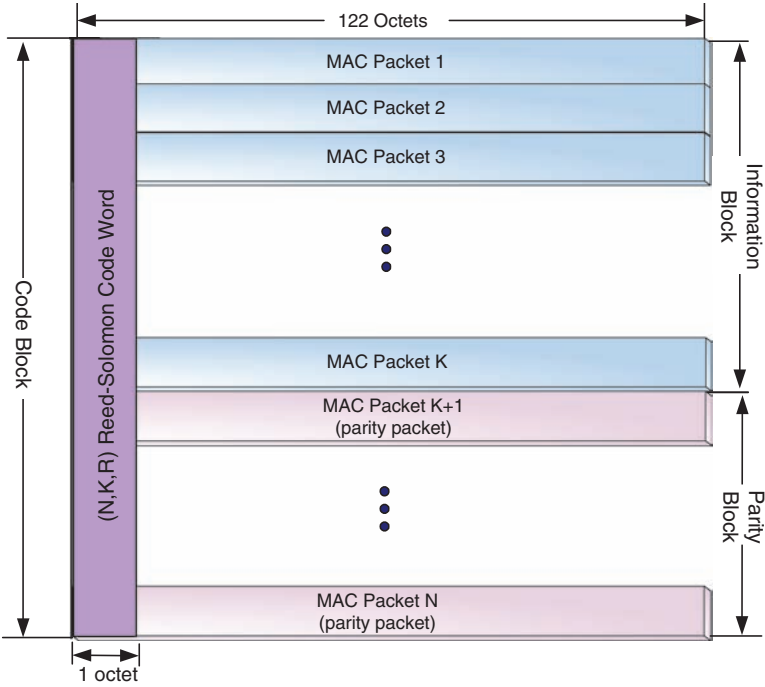

Fig. 7.23 Reed-Solomon code block in FLO

Figure 7.24 shows how the MAC Layer packets in a Reed-Solomon code block is sequenced to the four data frames within a superframe for transmission: the code block is split into four equal-size subblocks and each subblock is sent in a unique frame within the superframe. This process is repeated for every Reed-Solomon code block to be transmitted in a superframe. Since the sequencing process distributes the MAC packets in a Reed-Solomon code block evenly over the four data frames in a superframe, it increases the time-diversity gained across each code block.

The interleave and sequencer in Fig. 7.22 are designed in such a way that the MAC packet transmission pattern generated by the procedure for an MLC in a superframe has the characteristics as illustrated in Fig. 7.25. Each box represents a MAC layer packet. In this example, the MLC has two Reed-Solomon code blocks for the superframe):

- The MAC packets are transmitted in the same order as they are formed by the methods in Sect. 7.4.1. The number in each box indicates the corresponding packet’s order.
- Due to the MAC Layer Packet interleaver, any two consecutive packets that belong to a code block and are in the same data frame are separated by $n - 1$ packets belonging to other code blocks where n is the total number of the code blocks the MLC has in the superframe. This helps to disperse error bursts in each code block and increases the probability that the Reed-Solomon decoder can recover it. Please refer to [4] for more details on the interleaver.

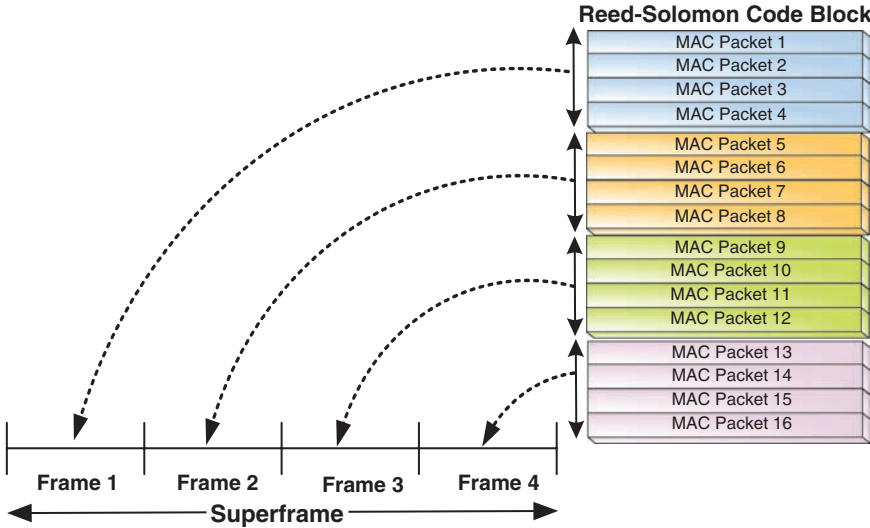

Fig. 7.24 Sequence MAC Layer packers in an R-S code block to data frames

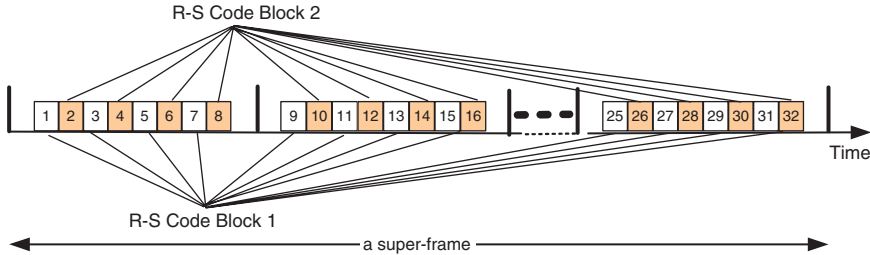

Fig. 7.25 Reed-Solomon code blocks sequenced to data frames in a super-frame

7.4.3 Time-Frequency Resource Allocation to MLCs

In the FLO system, the data carried in an MLC in a superframe is divided into four equal-size bursts and each burst is transmitted in a unique data frame in the superframe. The MAC Layer on the network allocates time-frequency resources in each data frame to the MLC. The allocation is in units of OFDM symbols on time domain and in units of slots on frequency time. The time-frequency allocation for an active MLC is identical in all the four data frames within a superframe and conveyed to the receiver by the following attributes for the MLC in the System Parameters Message transmitted in the OIS (see Fig. 7.26: an area with a unique color represents the time-frequency allocations for the corresponding MLC; the numbers in the box are stream index):

- *StartOffset*: the index of the first allocated OFDM symbol.
- *StartSlot*: the index of the lowest slot in the first allocated OFDM symbol.

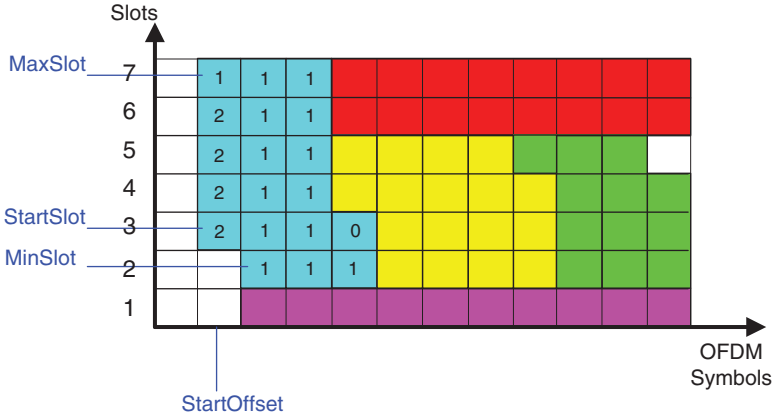

Fig. 7.26 Time-frequency allocation specification

- *MaxSlot*: the index of the highest slot in all the allocated OFDM symbols.
- *MinSlot*: the index of the lowest slot in the allocated OFDM symbols.
- *StreamLength*: it specifies the number of MAC Layer packets for each stream in the MLC. The total number of slots allocated to the MLC in the superframe can be determined from the total number of MAC Layer packets for the MLC in the superframe.

The area corresponding to the time-frequency allocation for an MLC in the time-frequency plot (Fig. 7.26) does not have to be a rectangular area. This flexibility offers the following advantages:

- Enables the FLO network to allocate bandwidth to an MLC that is very closely matched to what the MLC requires.
- Minimizes the number of slots that cannot be allocated due to constraint on the shapes of the allocated areas.

The time-frequency allocation is typically adjusted on a per-superframe basis according to the traffic variation. This mechanism allows the statistical multiplexing in an FLO Physical Layer Data Channel to be very efficient.

7.5 Control Layer

The control channel carries the control information that is required by FLO receivers to acquire and navigate the FLO data channels. The control information is carried in the following three types of control protocol messages:

- *Flow Description Message*: conveys information that maps upper layer flow ID to stream, MLC and RF Channel, and specifies the MLC parameters (e.g., transmit mode, Reed-Solomon code rate) and the stream parameters.

- *RF Channel Description Message*: conveys information about the RF Channels in use such as frequency and bandwidth, e.g. 5, 6, 7 or 8 MHz.
- *Neighbor List Description Message*: conveys information about the neighboring local-area e.g. RF Channels, WID, and LID. This information aids device transition to new local-areas.

The FLO system uses sequence numbers to indicate the versions of the control information. The sequence numbers are carried in the OIS that helps the FLO receiver determine if it has the latest control information. This allows the receiver to save power as the receiver will only decode the control channel when newer control information is present.

The control channel uses the Control Channel MAC Protocol to insert a special format MLC into the Physical Layer Data Channel (it does not use Stream Layer). The characteristics of the MLC mapped to the wide-area or local-area control channel in a superframe such as time-frequency allocation, transmit mode, Reed-Solomon code rates are carried in the System Parameters Message transmitted in the wide-area/local-area OIS channel in the same superframe.

7.5.1 Data Encapsulation

Each control protocol message is encapsulated in one or several Control Protocol Packets (CPP) for transmission. The CPP has the same size as the MAC Packet (122 octets) and there is one-to-one mapping from CPPs to Control Channel MAC Packets. The CPP structure is shown in Fig. 7.27.

The Control Protocol uses the CPPs to construct the Control Protocol Capsule. A Control Protocol Capsule is defined as a group of CPPs transmitted or received in a single superframe and its structure is shown in Fig. 7.28. The control information is

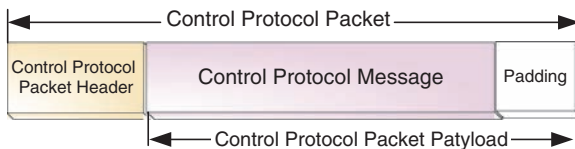

Fig. 7.27 Control Protocol Packet structure

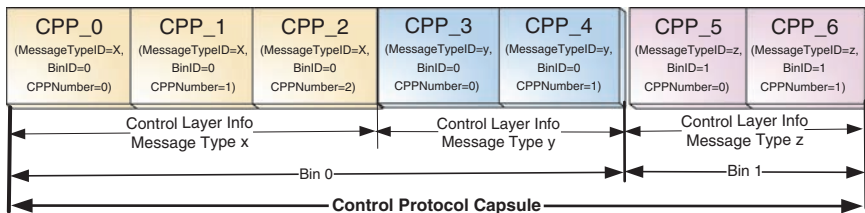

Fig. 7.28 Control Protocol Capsule Structure

organized into two logical groups called *bins* for efficient update purpose. Each bin has its own sequence number transmitted in the OIS to indicate its version, which allows the system to update the control information in a particular bin independently. Note the CPP header in the *first* CPP in a Control Protocol Capsule has a Fill Field where the MAC Layer will put the MAC Capsule Header (see Sect. 4.1).

Since the CPP has the same size as the MAC Packet, the Control Protocol Capsule size is always an integer multiple of the MAC Packet size. Each Control Protocol Capsule is carried in a Control Channel MAC Protocol Capsule (see Sect. 4.1).

7.6 Stream Layer

The Stream Layer maps the application flows to the streams and MLCs (the mapping is transmitted to the device in the Flow Description Message on the Control Channel). It receives data from application flows, constructs Stream Layer packets from the data and sends the packets to the Data Channel MAC protocol for transmission. The size of a Stream Layer packet is always an integer multiple of the MAC Layer packet size (122 octets).

The Stream Layer interface exposed to the upper layer supports two interface modes:

- *Transparent or Block Flow Mode* in which the Stream Protocol in the network receives a stream of 122-octet blocks from the Upper Layer and the peer protocol in the device delivers these fixed sized octet blocks to the Upper Layer. Each of the 122-octet blocks will be carried by a unique PLP. This mode is supported for streams 1 and 2.
- *Octet Flow Mode* in which the Stream Protocol in the network receives a stream of octets from the Upper Layer and the peer protocol in the device delivers a stream of octets to the Upper Layer. Stream Layer Packets constructed from the octet stream may have padding as the size of a Stream Layer Packet is always an integer multiple of the MAC Layer packet size. Stream 0 is operated in this mode.

7.7 FLO Air Interface Handling Scenarios at the Receiver

7.7.1 MLC Reception

The transmission for an MLC in a superframe consists of four equal-sized bursts with each burst transmitted in a unique frame. The time-frequency allocation for each MLC is identical for the four frames within a superframe and specified by the information transmitted in the OIS of the same superframe. The FLO receiver uses this information to locate the MLC in the superframe as shown in [Fig. 7.29](#).

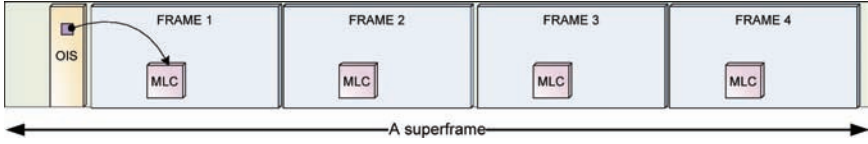

Fig. 7.29 Locating MLC Using OIS Information

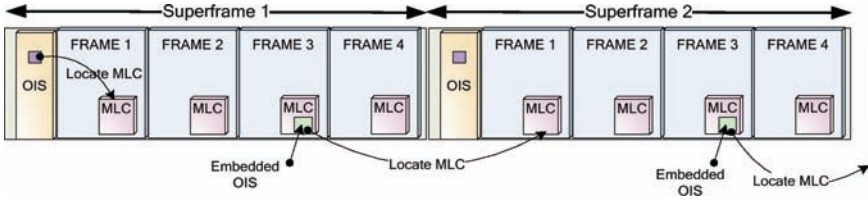

Fig. 7.30 Locating MLC Using Information in embedded OIS

The MAC protocol on the network copies the time-frequency allocation for an MLC in the *next* superframe to the *embedded OIS* (see Sect. 4.1). When the receiver needs to receive data in a specific MLC for a sustained period of time, it is more power efficient to utilize the embedded OIS. As shown in Fig. 7.30, the FLO receiver may use the embedded OIS received as part of the MLC payload in the current superframe to locate the MLC in the next superframe in which the MLC will be present, and avoid reading the OIS channel in every superframe.

The MLC reception on the FLO receiver can be very power efficient for the following reasons:

- The receiver only performs demodulation and decoding for the slots that are allocated to the MLC in the OFDM symbols that are allocated to the MLC. The FFT block in the receiver can be designed such that only the interlaces allocated to the MLC are demodulated.
- The embedded OIS allows decoding the OIS to be optional in superframes other than the first one in which the receiver starts the MLC reception.

7.7.2 Service Channel Switching

MLC switching on the FLO receiver is typically triggered by the user action like switching service channel on the receiver. A timeline for an FLO receiver switching from an old MLC to a new one is shown in Fig. 7.31:

1. The user selects a new service channel and the receiver is instructed to switch to the MLCs corresponding to the new service channel in the superframe 1.
2. The receiver decodes the System Parameters Message from OIS in superframe 2 and finds out it has the current control information based on the control information sequence number in the received System Parameters Message (see Sect. 7.5).

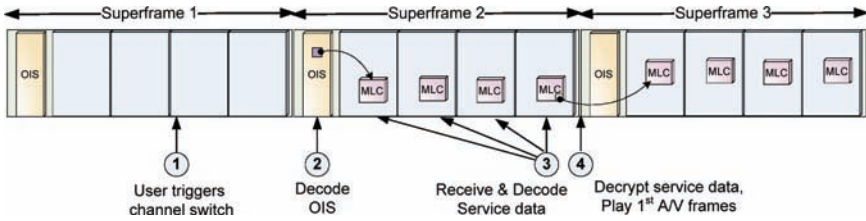

Fig. 7.31 Timeline for a device with current control channel data to acquire a real-time service

It then maps the flows in the new selected service channel to MLCs using the control information (Flow Description Message) and finds the locations of the MLCs in the superframe using information from the received System Parameters Message.

3. The device demodulates and decodes PLPs for the MLCs mapped to the flows in the new selected service from the four data frames in superframe 2, and Reed-Solomon decodes the PLPs to recover the service data after receiving the PLPs from the fourth data frame.
4. The service data is decrypted and the first video frame and the corresponding audio are played at the beginning of superframe 3. It is convenient to assume the first video frame is a frame like an Independent Decoder Refresh (IDR) frame that can be decoded independently.

7.8 Conclusions

MediaFLO is an open global technology standard that is purpose-built for mobile broadcast. This chapter gives an overview on the FLO Air Interface between a MediaFLO network and a device. The focus is on the efficient techniques that FLO is able to employ due to lack of constraint on backward compatibility with legacy technology. These techniques allow FLO to offer the following unique advantages:

- *Low receiver power consumption:* FLO makes the MLCs carrying service data distinguishable on the Physical Layer, which enables the FLO receiver to consume power only on receiving and decoding the desired data. The embedded OIS can allow the receiver reduced power consumption by eliminating the need for decoding OIS most of the time.
- *Fast service channel switching time:* The FLO superframe structure and one second superframe duration allows for fast service channel switching while maintaining high time diversity gains.
- *High spectral efficiency:* Both simulations and field tests have shown FLO capable of high spectral efficiency [2, 9]. FLO achieves this by offering significant time and frequency diversity gains and using Turbo code instead of convolutional code.

- *Efficient statistical multiplexing*: The variable bandwidth available for allocation to each MLC in an FLO system can be closely matched to service requirements. This bandwidth allocation can be adjusted dynamically on a per-superframe basis according to the traffic variation. This capability allows effective and efficient statistical multiplexing to be implemented across the FLO Physical Layer.

Appendix

Table 7.6 FLO System parameters for different RF channel bandwidths

Parameters	5 MHz	6 MHz	7 MHz	8 MHz
Chip rate (FFT bandwidth)	4.625 MHz	5.55 MHz	6.475 MHz	7.4 MHz
Chip duration	0.21622 μ s	0.18018 μ s	0.15444 μ s	0.13514 μ s
Number of subcarriers (FFT size)	4,096	4,096	4,096	4,096
Subcarrier spacing	1.129 kHz	1.355 kHz	1.581 kHz	1.807 kHz
FFT interval (useful OFDM symbol interval)	885.64 μ s (4,096 chips)	738.02 μ s (4,096 chips)	632.59 μ s (4,096 chips)	553.53 μ s (4,096 chips)
Cyclic prefix (flat guard interval)	110.70 μ s (512 chips)	92.25 μ s (512 chips)	79.07 μ s (512 chips)	69.19 μ s (512 chips)
Window interval	3.68 μ s (17 chips)	3.06 μ s (17 chips)	2.63 μ s (17 chips)	2.30 μ s (17 chips)
(Effective) OFDM symbol interval	1,000.00 μ s (4,625 chips)	833.33 μ s (4,625 chips)	714.29 μ s (4,625 chips)	625.02 μ s (4,625 chips)
Number of guard subcarriers	96	96	96	96
Number of active subcarriers	4,000	4,000	4,000	4,000
Number of pilot subcarriers	500	500	500	500
OFDM symbols per superframe	1,000	1,200	1,400	1,600

Table 7.7 FLO Physical Layer Data Rates for Different RF Channel Bandwidths

Transmit mode	Modulation	Turbo code rate	5 MHz Physical Layer data rate (Mbps)	6 MHz Physical Layer data rate (Mbps)	7 MHz Physical Layer data rate (Mbps)	8 MHz Physical Layer data rate (Mbps)
0	QPSK	1/3	2.33	2.80	3.27	3.73
1	QPSK	1/2	3.50	4.20	4.90	5.60
2	16-QAM	1/3	4.67	5.60	6.53	7.47
3	16-QAM	1/2	7.0	8.40	9.80	11.20
4	16-QAM	2/3	9.33	11.2	13.07	14.93
5 ^a	QPSK	1/5	1.40	1.68	1.96	2.24
6	Layered QPSK with energy ratio 4	1/3	4.67	5.60	6.53	7.47
7	Layered QPSK with energy ratio 4	1/2	7.00	8.40	9.80	11.20
8	Layered QPSK with energy ratio 4	2/3	9.33	11.20	13.07	14.93
9	Layered QPSK with energy ratio 6.25	1/3	4.67	5.60	6.53	7.47
10	Layered QPSK with energy ratio 6.25	1/2	7.00	8.40	9.80	11.2
11	Layered QPSK with energy ratio 6.25	2/3	9.33	11.20	13.07	14.93

^aThis mode is used for the OIS channels only.

References

1. CDMA2000 High Rate Packet Data Air Interface Specification, 3GPP2 C.S2024-A v1.0, March 2004.
2. M. Chari, F. Ling, A. Mantravadi, et al, "FLO physical layer: an overview", *IEEE Trans. Broadcasting*, vol. 53, no. 1, pp. 145–160, 2007.
3. FLO Forum Web Site <http://www.floforum.org/>
4. Forward Link Only Air Interface Specification for Terrestrial Mobile Multimedia Multicast, TIA-1099, Aug. 2006.
5. Forward Link Only Transport Specification, TIA-1120.
6. W. C. Jakes, Ed., *Microwave Mobile Communications*. Piscataway, NJ: IEEE Press.
7. Y. Li, "Pilot symbol aided channel estimation for OFDM in wireless systems", *IEEE Trans. Vehicle Technology*, vol. 49, pp. 1207–1215, July 2000.
8. A. Mattson, "Single frequency networks in DTV", *IEEE Trans. Broadcasting*, vol. 51, no. 4, pp. 413–422, 2005.
9. "MediaFLO Field Test Report", QUALCOMM White Paper. Available at <http://www.qualcomm.com/mediaflo>
10. MediaFLO USA Web Site <http://www.mediaflousa.com/>
11. *Physical Layer Standard for cdma2000 Spread Spectrum System-Release C, 3GPP2 C.S2002-C v1.0, May 2002*
12. M. Speth, S. A. Fechtel, G. Fock, and H. Meyr, "Optimum receiver design for wireless broadband systems using OFDM. I", *IEEE Trans. Communications*, vol. 47, no. 11, 1999.
13. TIA Web Site <http://www.tiaonline.org/>